

Mounting and installation manual

Sliding gate operators PULL T24, -T24speed



Index

	Important warning and safety notes for installation and operation	3
1.	Notes, general characteristics, function, technical data	4
2.	Mounting	5
	Emergency release in case of power failure (note for the user)	8
3.	Control unit, overview.....	9
	Warnings - connection works	10
	Programming, Structure of the menu	11, 12
	Connections and adjustments	13
	Button/switches.....	13
	Safety.....	15
	Motor.....	19
	Operating mode.....	20
	Lights/lamps.....	21
	Diagnosis	23
4.	Connection of radio receiver	24
5.	Initial operation	25
5.1	Battery connection	27
6.	Error diagnosis	28
7.	Cable plan	29
8.	Dimensioned drawing	30
	Declaration of incorporation	31



Important warning and safety notes for installation and operation

- These installation and operating instructions form an integral part of the product “sliding gate operator”. They have been specifically written for professional installers trained and skilled in the trade and should be carefully read in their full length before carrying out the installation. They describe the proper installation and operation of the sliding gate operator only, not of the overall device “automatic gate”. After the installation this manual has to be handed over to the user.
- Installation, connection, adjustments, putting into operation, and servicing may only be carried out by trained professionals in full accordance with these installation- and operating instructions.
- Before carrying out works at the gate-system, the power supply has to be turned off.
- The EU Machine Directive, laws and rules concerning the prevention of accidents, and laws and standards which are in force in the EU and in the individual countries have to be strictly followed.
- The TOUSEK Ges.m.b.H. cannot be held liable for any claims resulting from disregards of the laws and standards in force during the installation and operation.
- The packaging materials (cardboard, plastic, EPS foam parts and filling material etc.) have to be properly disposed of in accordance with the applying recycling- and environmental protection laws. They may be hazardous to children and therefore have to be stored out of children’s reach.
- The product is not suitable for installation in explosion-hazardous areas.
- The product may only be used in accordance with its original purpose, for which it has been exclusively designed, and which is described in these installation and operating instructions. The TOUSEK Ges.m.b.H. rejects any liability if the product is used in any way not fully conforming to its original purpose as stated herein.
- **Children have to be instructed**, that the gate facility as well as the belonging parts may not be used improperly, e.g. for playing. Furthermore handheld transmitters have to be kept in safe places and other impulse emitters as buttons and switches have to be installed out of children’s reach.
- Before beginning with the installation the installer has to make sure that all mechanical components of the gate facility, like carrier profile/rail, gate frame and panels, guiding elements etc. are sufficiently supportive and resistant for the purpose of gate automation.
- All electrical installations have to be made in full conformity with the applying rules and laws (e.g. using a fault current circuit breaker, proper grounding etc.).
- **An all-pole disconnecting main switch with a contact opening-gap of minimum 3 mm has to be foreseen.**
- The electric motor heats up during operation. Therefore the device should only be touched after it has cooled off.
- **After installation the proper function of the gate facility and the safety devices has to be checked!**
- **After putting the gate in operation, the gate system must be checked with a suitable force measuring device in accordance with the applicable standards EN 12453 or national regulations.**
- The TOUSEK Ges.m.b.H. rejects any liability for claims resulting from usage of the product in combination with components or devices which do not fully conform to the applying safety laws and rules.
- Only original spare- and replacement parts may be used for repair of the product.
- The installer has to inform the user about all aspects of the automatic operation of the complete gate facility, as well as about emergency operation. The installer further has to supply to the user all instructions relating to the safe operation of the gate facility. The installation and operating instructions also have to be handed over to the user.
- **Please notice that the warranty will not be applicable if the label with the engine number has been removed or damaged.**



Maintenance

- **Disconnect the power supply before installation, maintenance or repair work.**
- **Maintenance works may only be carried out by qualified personnel.**
- **Check the proper sensitivity setting of the ARS safety reverse system once a month.**
- **Check the proper function of the emergency release mechanism periodically.**
- **Check if all mounting screws are securely fastened periodically.**
- **Remove dirt deposits from the operator and gear rack periodically.**
- **Maintenance and servicing of the complete gate facility has to be carried out according to the gate builder’s/ installer’s instructions.**
- **With every maintenance, the door system must be checked with a suitable force measuring device in accordance with the applicable standards EN 12453 or national regulations.**

Caractéristiques PULL T24, -T24speed

- Programmable control panel accessible from exterior with illuminated display in english
- Direct connection of 8,2 kOhm contact barriers (safety sensing edges-2-channels)
- Adjustable soft stop (no loss of force even with reduced revolution speed)
- Three operating modes (impulse, automatic and dead man)
- Adjustable partial opening
- Built in control board in separate housing
- Safety system ARS (automatic reversal system)
- Self locking worm gear
- Emergency release, lockable with profile half cylinder (3 keys included) - changeable, thus incorporation into an existing house key system is possible.
- Backup battery can be integrated (optional)
- 24V Motor
- Drive unit (gearbox unit) made of steel and runs in an oil bath
- Worm gear and worm wheel made of tempered steel
- Permanently selflearning force
- Current consumption in standby is minimal thanks to switch-mode power supply



General

During the development of the new operator generation Tousek PULL T24, -T24speed special attention has been paid to a quick and simple installation and a troublefree operation, together with the proven quality and reliability. Accordingly, many clever details have been built into the operator - from the automatic learning of gate end positions, to the control board with removable clamps an integrated safety sensing edge analysis, to an easy programmable text display - which make it particularly user-friendly. The drive unit itself consists of an electric motor and a worm gearing, accommodated in a robust aluminium housing, and - together with the integrated microprocessor control unit and the safety reverse system ARS - forms a compact device with small overall dimensions. The safety reverse system ARS senses obstacles during opening and closing of the gate and permits a continuous adjustment of the drive force. Following the Tousek tradition, all operator components have been built in a particularly robust and resistant way to guarantee the safe and reliable operation even in the most adverse weather conditions. Additional improvements are for example: control board with display is accessible from outside, the separate control board housing, which double protects this sensible part, or an oil bath which ensures that the motor/gearing components can move in an optimal way in all temperatures with perfect lubrication and cooling effect. The installation of the PULL T24, -T24speed is possible for new or already existing sliding gates in a simple and fast way.

Functions

The integrated control board has three operation modes : **impulse mode** (with button/switch function open and close), **automatic mode** (automatic closing) and **dead-man mode** (the gate moves as long as the button/switch is pressed)
Not only the possibility of connecting a button/switch OPEN / CLOSE / STOP, photocells and a safety device, but also a pedestrian entry button/switch which enables the partial opening of the gate. The system has 230V output terminals, for connecting a signal lamp. Further it's equipped with slots for a pluggable radio receiver and an additional module (for courtyard lamp or for evaluating the gate state).

Technical data

Sliding gate operator PULL-	T24	T24speed		T24	T24speed
Control board	intégrée		Max. drive distance	30m	
Power supply Motor tension	230Va.c. 50Hz 24V d.c.		Duty cycle (S3 mode)	40–80%	
Max. current consumption (excl. equipment)	1A		Ambient temperature	-20° +40°C	
Gear wheel	Z16M4	Z20M4	Protection class	IP44	
Max. gate weight	600kg	400kg	Speed sensor	■	■
Speed	13m/min	16m/min	Article number	11110540	11110550
Torque	20Nm				
Optional equipment	pluggable receiver • additional module for courtyard lamp/control lamp • additional module for evaluation of gate status • bracket with cap rail included • radio transmission system TX 310 • inductive system TX 400i				

*** at low temperatures or with rough running gates a reduction in speed is possible depending on system used (24V DC motor)!**

Motor selection by using a spring scale	T4speed / T5	T8	T10	T15	T24	T24speed
Attach the spring scale to the gate at approx. the height of the rack. Then pull horizontally and without rocking at motor speed. Compare the max. detected tractive force with the guide values listed on the right.	up to 20kg	up to 30kg	up to 40kg	up to 60kg	up to 25kg	up to 20kg

Technical layout PULL T24, -T24speed

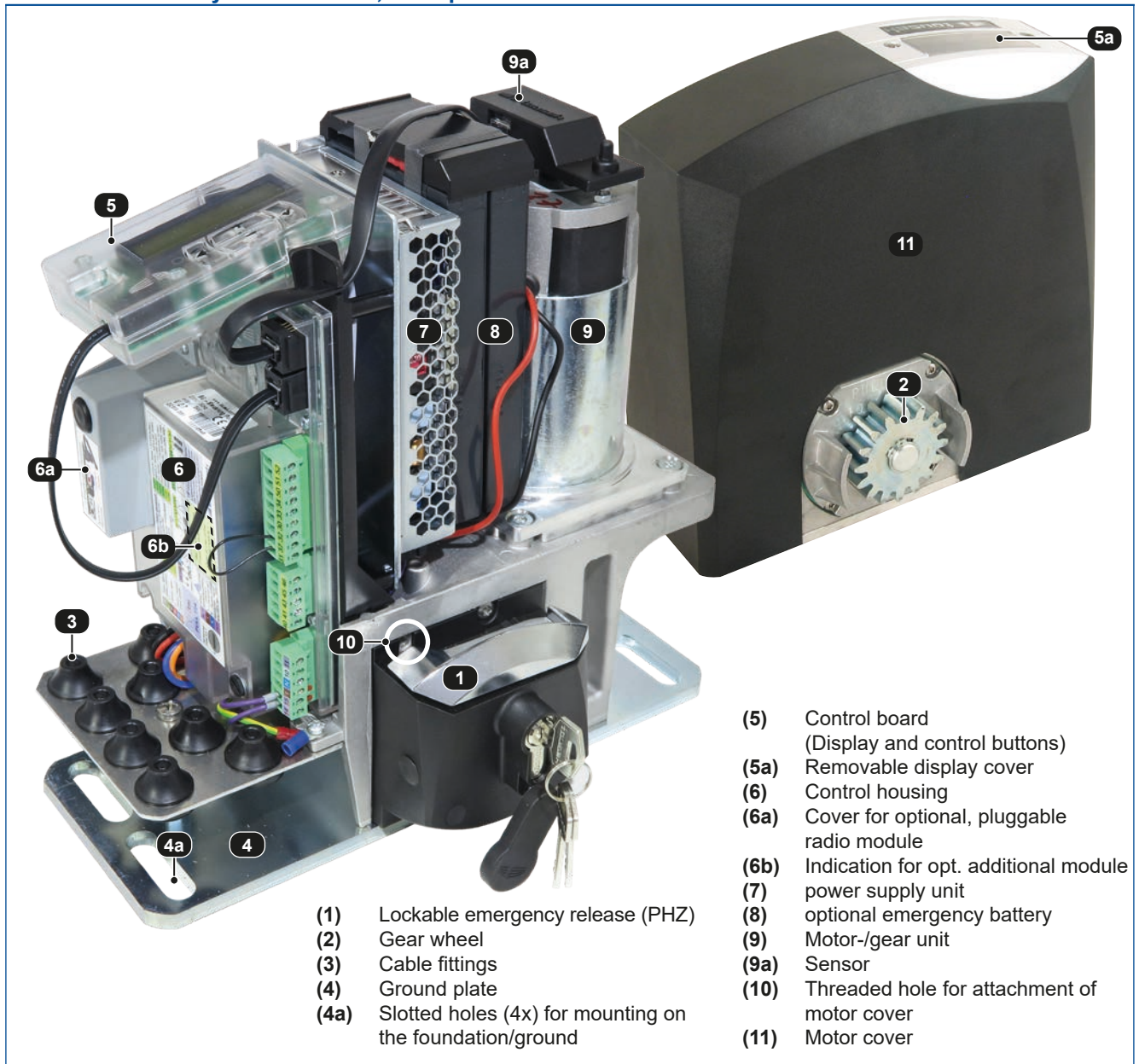

General installation notes

Before installing the Tousek PULL T24, -T24speed sliding gate operator we recommend checking the following points:

- **Checking the gate structure:**

On a gate which travels on floor rails please check the bottom rollers and the upper guide rollers and make sure that there is no undue friction or jamming.

On a cantilever gate please check if the gate can be moved out of its end-positions without undue effort.

- The gate must travel in a stable manner without lateral movements of the gate panel.
- Make sure that the gate travels in a regular way without undue friction or jamming along the whole travel length.
- **Make sure that there are stoppers at both ends of the track, preventing the gate from running over its travel limit.**

**ATTENTION !**

- **ATTENTION: Mechanical limits are necessary!**
- **ATTENTION: the sliding gate operator PULL T24, -T24speed has been developed and designed for the automation of horizontally travelling sliding gates. Gates on sloping tracks (i.e. gates which follow an inclined, non-horizontal, travel path) must not be automated without additional safety devices (which make sure that the gate cannot start moving on its own from any gate position).**

After installing the protection tubes (**check cable exit of operator (3)**) and having finished the concrete foundation, the motor has to be bolted through the 4 slotted holes (**4a**) to the concrete foundation. It is particularly important that the operator is mounted parallel to the gate panel, and that the measurements given in the drawing are kept.



NOTE concerning cable laying

- The electric cables have to be laid in insulating sleeves which are suitable for underground usage. The insulating sleeves have to be lead into the inner of the operator housing (see picture).
- 230V cables and control lines have to be laid in separate sleeves.
- Only double-insulated cables, which are suitable for underground usage may be used.
- In case that special regulations require another type of cable, cables according to these regulations have to be used.

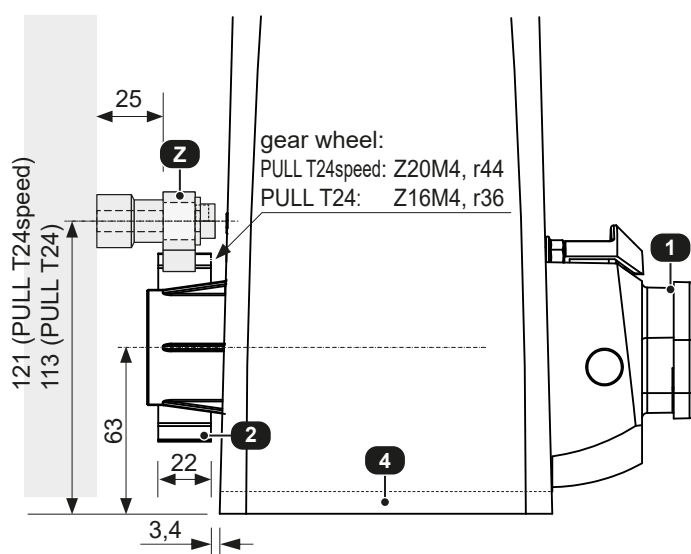

- (1) lockable emergency release (PHZ)
- (2) gear wheel
- (3) cable
- (4) ground plate
- (4a) slotted holes (4x) for connection on the ground
- (Z) steel gear rack

Dimensions in mm

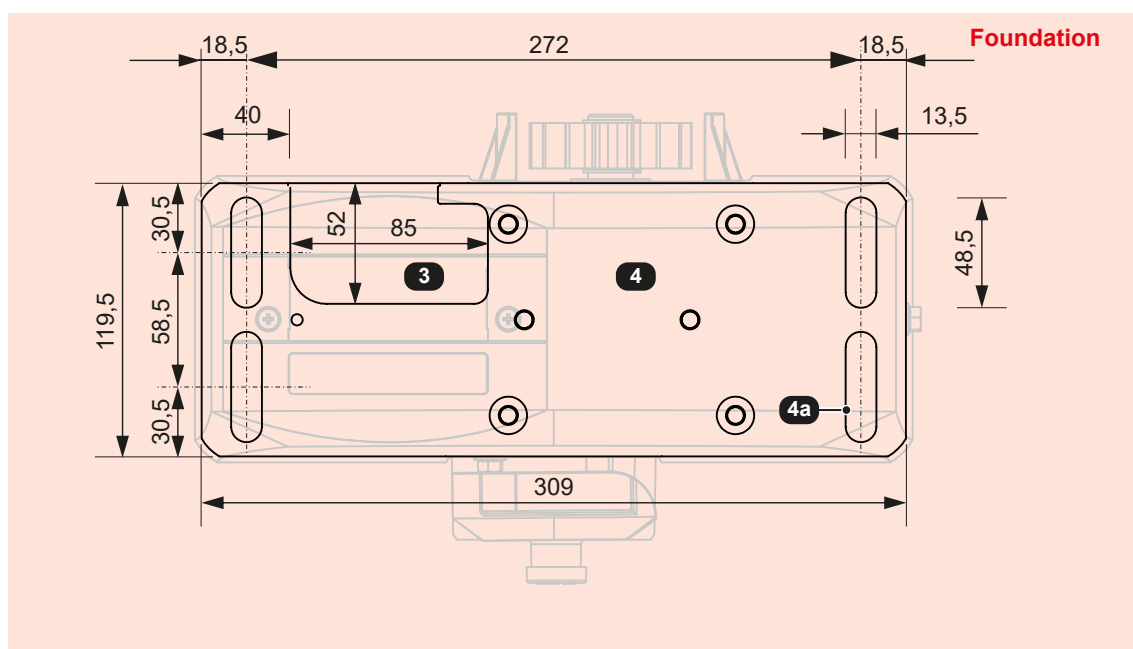

2.2 Installation of the gear rack

Installation

- Disengage the motor from the output drive pinion with the emergency release lever (see emergency release for instructions) and open the gate completely.
- Install the spacer tubes (D) with the help of the bolts and washers on the first meter of gear rack
- Make sure that the bolts/screws sit in the top end of the vertical slots (L), then tighten them.
- Place the first gear rack element on the drive pinion and fix it in place with a screw clamp.
- Move the gate by hand until reaching the end of the first gear rack element, then weld the first, second, and third spacer tube to the gate
- Proceed with the other gear rack elements in the same manner.
- **Before fixing the second meter of gear rack it is essential to place another gear rack element under the first and second gear rack elements, thereby making sure that the gearing module between the two gear rack elements will be exactly kept (see illustration).**
- After installation of the gear rack please loosen the fastening bolts slightly and rise the gear rack a little along the vertical slots, creating a **distance of approx. 1 mm between the flank of the drive pinion and the gear rack.**
- The gear rack elements can also be installed without welding, i.e. by screwing them to the gate frame together with the spacer tubes. Apart from that the gear rack elements

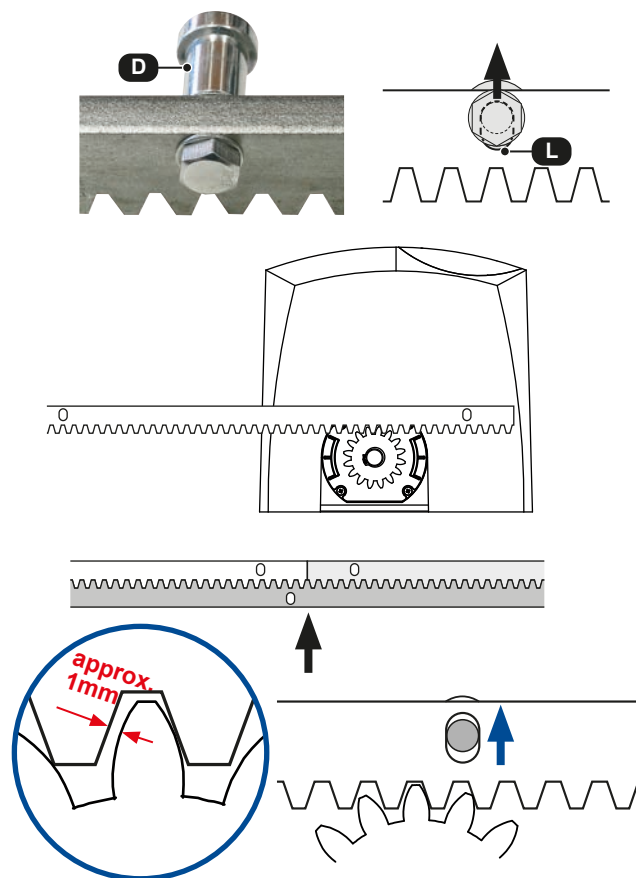

Attention

- **Do not weld the individual gear rack elements together!**

2.3 Emergency release in case of power failure (note for the user)

PULL T24, -T24speed

In case of a power failure or other defect the drive pinion can be disengaged from the gearmotor as follows:

- **Switch off power supply** 
- Slide key-cover **(A)** slightly to the front and turn it away. Insert the key and turn it clockwise to its limit stop (the emergency release mechanism can be key-locked both in the engaged and in the disengaged position).
- Turn the handle 180° counter-clockwise (viewed from above). The gate can now be manually opened or closed.

Re-engaging the emergency release mechanism:

To return to normal motor operation please turn the handle back to its original position (i.e. 180° clockwise)



Important

- after the handle is back in normal position, slowly move the gate manually in its travel direction until you can hear that the gearing has re-engaged!

Then lock it again and remove the key.

With next command the motor searches the open position (a new learning of end positions is not necessary).

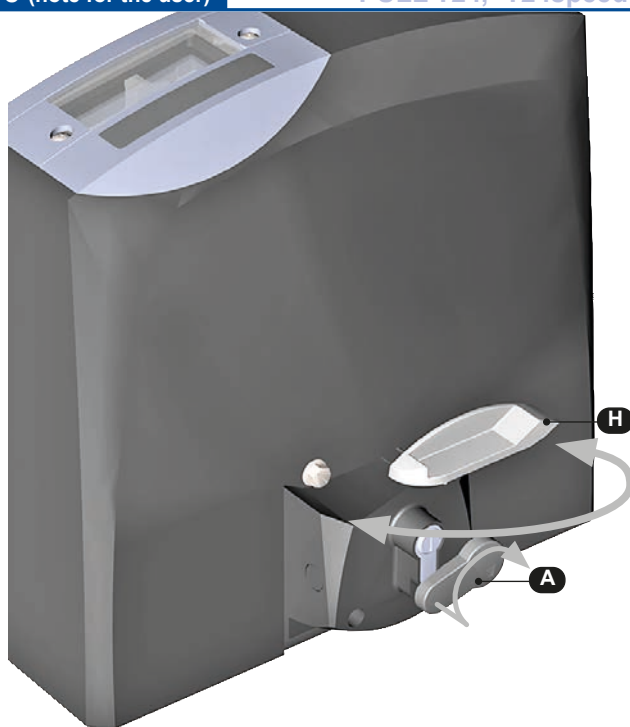

Handle in picture shows unlocked position

2.4 Exchanging the lock half cylinder

Sliding gate operator PULL T24, -T24speed

- Remove the screw protection cap and turn out the screw **(S)**.
- Turn the cylinder protection cap down, insert the key, turn it approx. 90° clockwise, and pull out the cylinder.
- To re-insert the cylinder please carry out the above steps in the reverse order

Lock half cylinder (PHZ) with 3 keys (product code: 13300220)

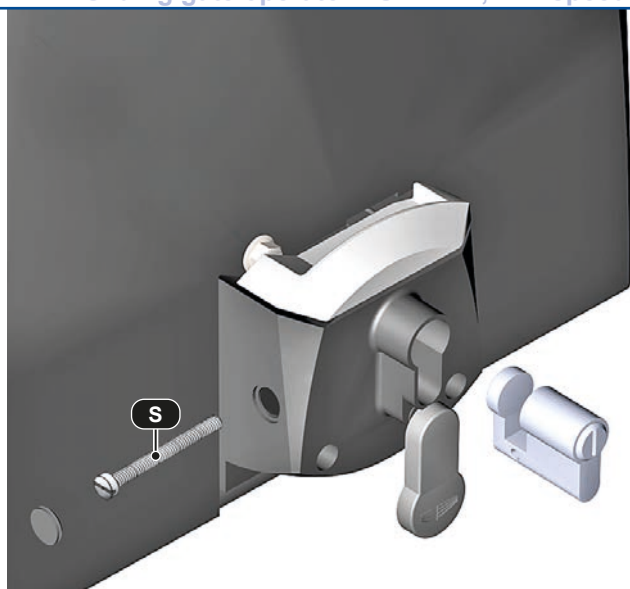
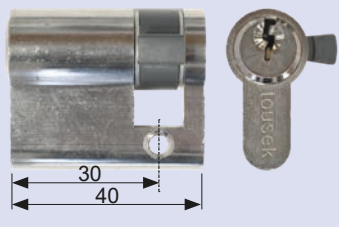

2.5 Dismantling

The dismantling of motor is made the other way around of mounting.



Before dismantling please plug off power supply of motor !

Overview of the control unit

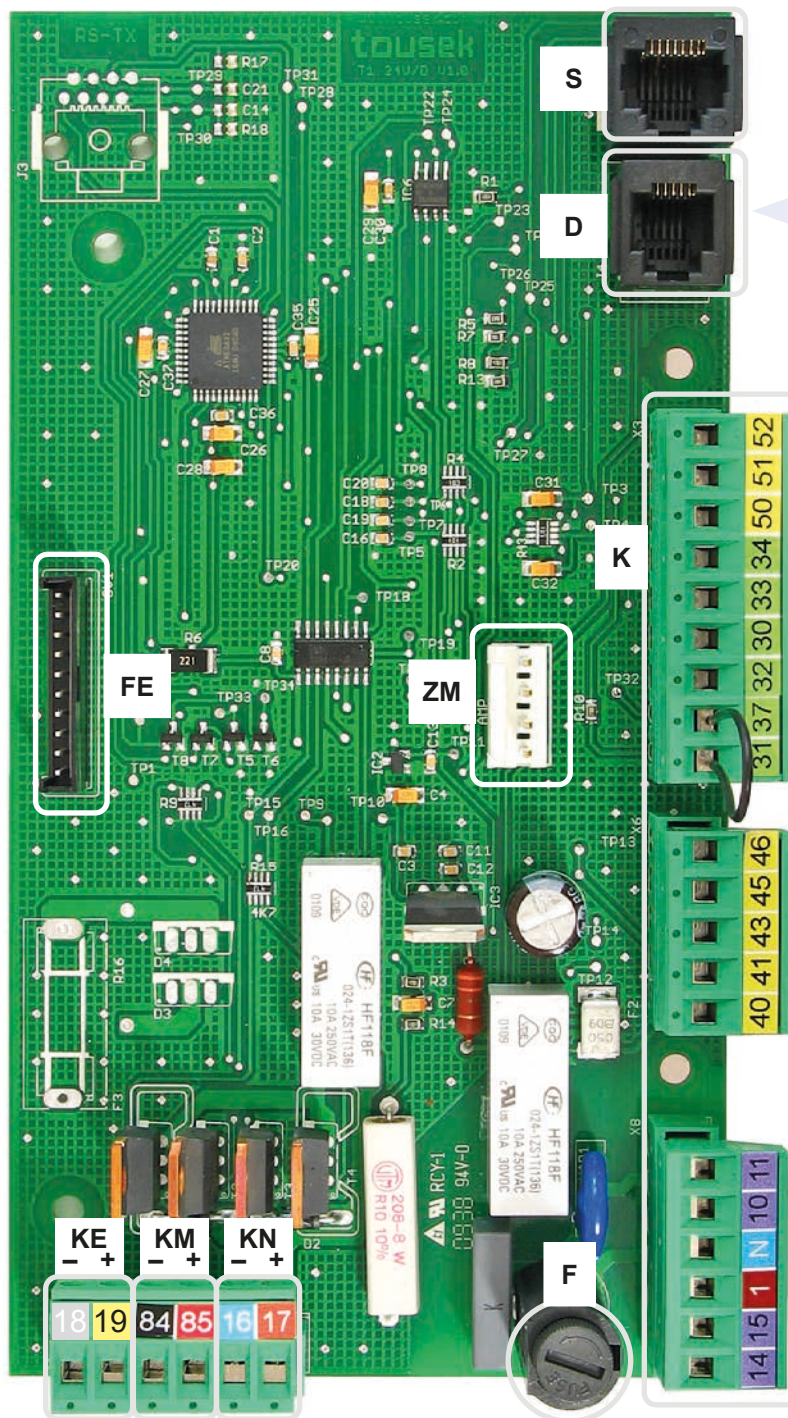

Important

The optional „tousek-connect“ or the „tousek service interface“ must be connected with socket (D)!



Attention

During connection, adjustment and maintenance works please take care, that the electronic circuit board won't be damaged by moisture (rain).



Grounding

The grounding connection is made on the operator housing with the designated grounding screw!

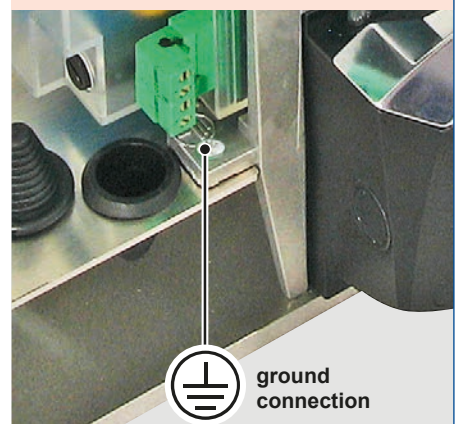

ground connection

Elements of control board

- (K) Terminal blocks
- (KE) Connector for battery 24Vd.c. (optional)
- (KM) Motor clamps
- (KN) Power supply low tension 24Vd.c.
- (S) Sensor plug
- (D) Display plug
- (FE) Slot for optional radio receiver
(→ page 24 for connection)
- (ZM) Connection slot for optional module
(→ page 22)
- (F) Safety fuse T 4A



Attention

- Before taking off the control cover, the mains switch must be turned off!
- If the control is power supplied, its inner part is under tension.
- In order to avoid electrical strokes, the safety regulations have to be kept.
- The device may only be connected by trained professionals



- The product is not suitable for installation in explosion-hazardous areas.
- An all-pole disconnecting mains switch with a contact opening gap of min. 3 mm has to be foreseen. The gate facility has to be secured according to the valid safety regulations!
- **IMPORTANT:** The control lines (buttons, radio, photocells, etc.) have to be laid separately from the 230V lines (supply line, motors, signal lamp).



Safety sensing edges

Function main safety sensing edge (MCE):
Safety during closing
Function side safety sensing edges (SE):
Safety during opening

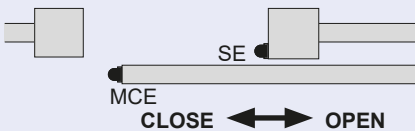

If no stop switch is connected, terminals 31/37 have to be wire-bridged.

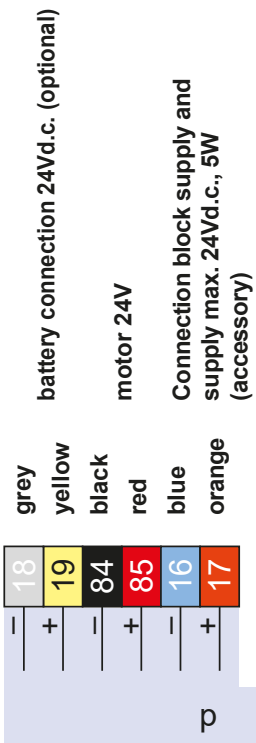
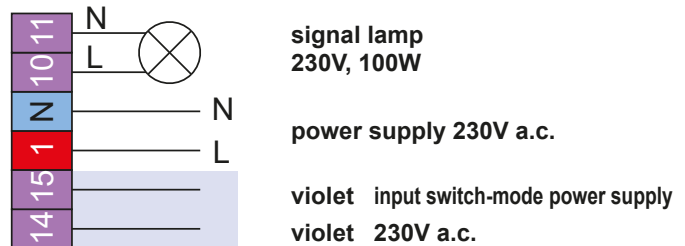
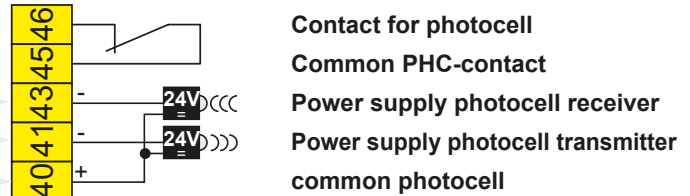
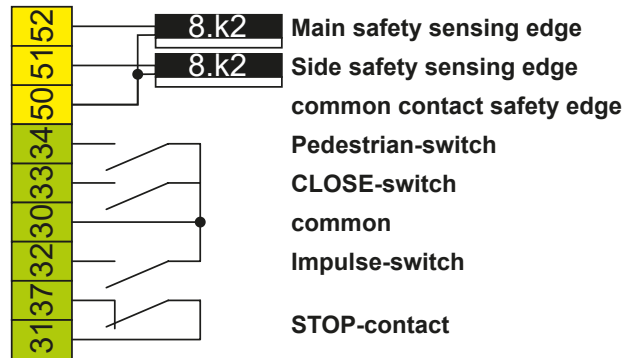

Terminals 40/41 and 40/43 in gate position CLOSE (ready for use) are in eco mode (= without tension).

Important: no external accessories are allowed on these terminals!



The stop input has no emergency stop function! - In order to ensure the emergency stop function, provide the supply line with an all-pole disconnecting emergency stop switch, that locks after actuation!

Programming buttons

Adjustment - overview



- Before starting the programming, please choose the language. Use the buttons **+** or **-** to choose menu language and confirm with **✓**.
- Note: Language selection can also be chosen by pressing the ESC button (**↵**) for 5s, from any position in menu.

- For programming please remove cover (A) of control device (loosen 2 bolts).
- The text display (T) informs you about operating status, chosen menus and the adjustment of various parameters..
- The programming of the control is carried out with the help of four buttons (**+**, **-**, **✓** (=Enter) and **↵** (=Escape).
- Scrolling through the available menu points (up/down) or the adjustment of a parameter (value increase/decrease) is carried out with buttons **+** and **-**. **AUTO-COUNT**: when holding one of the buttons the value changes automatically.
- When pressing the **✓**-button ea confirmation for entering the shown menu point, resp. for accepting the shown value of a parameter is given.
- When pressing the **↵**-button you return to the superior menu point. Possibly changed adjustments of a parameter are rejected with this button (the former values will remain).
- **AUTO-EXIT**: if no button is pressed during 1 min. then the menu switches automatically to the "ready" menu (without saving changed parameters).

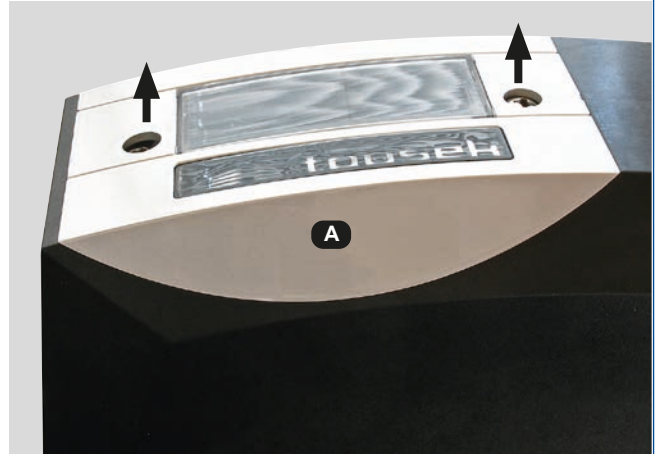

Programming menu

Adjustment - overview



- The program menu is divided into "BASIC SETTINGS" and "MENU CONTROL"

BASIC SETTINGS

- **When entering the programming of the control unit for the first time you will see the BASIC SETTINGS**
- Here the necessary adjustments which are necessary for the use of the operator/gate can be set quickly.
- For advanced settings/programming please choose the menu point "menu (control)".

MENU CONTROL

- For further programming you will reach immediately the MENU (CONTROL) (Basis settings are skipped)
- The menu control includes all kinds of settings.



The different menu points are indicated as follows:

- = selectable setting ⊙ = factory settings ⇌ = status display
 G = shows the menu points which are in the "BASIC SETTINGS"

Main layer	Sub layer	Settings/adjustments
button/switches ➔ page 13	impulse button	<input type="radio"/> OPEN/STOP/CLOSE <input type="radio"/> OPEN/CLOSE/OPEN <input type="radio"/> OPEN <input type="radio"/> DEAD MAN
	pedestrian button	<input type="radio"/> OPEN/STOP/CLOSE <input type="radio"/> OPEN/CLOSE/OPEN <input type="radio"/> OPEN <input type="radio"/> Impulse OPEN <input type="radio"/> DEAD MAN ¹⁾
safety ➔ page 15	photocell	<input type="radio"/> active <input type="radio"/> not active
	main safety edge	<input type="radio"/> active <input type="radio"/> radio edge TX <input type="radio"/> TX 400 <input type="radio"/> not active
	side safety edge	<input type="radio"/> active <input type="radio"/> radio edge TX <input type="radio"/> TX 400 <input type="radio"/> not active
	photoc.-function	<input type="radio"/> when closing reverse <input type="radio"/> stop - after release open <input type="radio"/> during close stop, then close
	PHC-pause time	<input type="radio"/> no influence of photocell <input type="radio"/> abort of pause time <input type="radio"/> re-start of pause time <input type="radio"/> immediate close after opening
	PHC-self test	<input type="radio"/> active <input type="radio"/> not active
motor ➔ page 19	max. force	<input type="radio"/> 50...100% [increment 5] <input type="radio"/> = 100%
	ARS-response time	<input type="radio"/> 0,15...0,95s [increment 0,05] <input type="radio"/> = 0,50s
	speed	<input type="radio"/> 55...100% [increment 5] <input type="radio"/> = 100%
	soft stop way	<input type="radio"/> 0...2m [increment 0,1] <input type="radio"/> = 0,5m
	soft speed	<input type="radio"/> 10...50% [increment 5] <input type="radio"/> = 40%
	limit position OPEN	<input type="radio"/> 0...-30 [increment 1] <input type="radio"/> = -5
	limit position CLOSE	<input type="radio"/> 0...-30 [increment 1] <input type="radio"/> = -5
operating mode ➔ page 20	impulse mode	<input type="radio"/> stop, start of pause time <input type="radio"/> impulse suppression when opening <input type="radio"/> pause time extension
	opening direction	<input type="radio"/> <<<- left <input type="radio"/> ->>> right
	operating mode	<input type="radio"/> impulse mode <input type="radio"/> aut. close 1...255s [increment 1]
	partial opening	<input type="radio"/> 10...100% [increment 1] <input type="radio"/> = 30%
	automatic mode	<input type="radio"/> complete/partial opening <input type="radio"/> only complete opening <input type="radio"/> only partial opening
	pause time logic	<input type="radio"/> no influence <input type="radio"/> always open in automatic mode
lights/lamps ➔ page 21	prewarning OPEN	<input type="radio"/> OFF, 1...30s <input type="radio"/> = OFF
	prewarning CLOSE	<input type="radio"/> OFF, 1...30s <input type="radio"/> = OFF
	additional module	<input type="radio"/> yard/control light <input type="radio"/> status display 1 <input type="radio"/> status display 2
	courtyard light ¹⁾	<input type="radio"/> OFF, 5...950s <input type="radio"/> = OFF
	control lamp ¹⁾	<input type="radio"/> illuminates when opening/closing <input type="radio"/> blinks slowly / illuminates / blinks <input type="radio"/> illuminates in open position
diagnosis ➔ page 23	status display	↔ status display of all inputs
	delete position	<input type="radio"/> NO <input type="radio"/> YES
	factory setting	<input type="radio"/> NO <input type="radio"/> YES
	software version	↔ show software version
	serial number	↔ show serial number
	protocol	↔ show protocol notes
	status sensor	↔ show sensor

Note: some adjustments regarding function or operating logic can only be executed if gate is closed and if the display shows „ready“.



*) if impulse button is set to DEADMAN, then the pedestrian and close button are also set automatically to DEADMAN mode. (not selectable under „pedest.- button“)

¹⁾ The menu points courtyard lamp and control lamp will only appear on display if in menu „Additional module“ courtyard lamp/control lamp is selected.



tousek

DIGITAL



integr. control board for sliders PULL T24, -T24speed



Warning notes

- Before taking off the control cover, the mains switch must be turned off!
 - If the control is power supplied, its inner part is under tension.
 - In order to avoid electrical strokes, the safety regulations have to be kept.
 - The device may only be connected by trained professionals.
- 
- The product is not suitable for installation in explosion-hazardous areas.
 - An all-pole disconnecting mains switch with a contact opening gap of min. 3 mm has to be foreseen. The gate facility has to be secured according to the valid safety regulations!
 - **IMPORTANT:** The control lines (buttons, radio, photocells, etc.) have to be laid separately from the 230V lines (supply line, motors, signal lamp).



The different menu points are indicated as follows:

○ = selectable setting ⊙ = factory settings ⇌ = status display

 shows the menu points which are in the "BASIC SETTINGS"

- A general status display of all inputs can be found in the menu DIAGNOSIS / STATUS DISPLAY

Button/switches

Connections and adjustments

Impulse button (terminals 30/32)

Buttons/switches

- ⊙ **OPEN/ STOP / CLOSE impulse repetition** (factory settings): After a command of the impulse switch the motor starts an open or close movement. If the impulse switch is pressed again during this movement, the motor stops. With the next command, the motor drives in the opposite direction of the last gate movement.
- **OPEN / CLOSE / OPEN impulse repetition:** After a command of the impulse switch the motor starts an open or close movement. If the impulse switch is pressed again during this movement, the motor reverses.



- In this operation mode it is not possible to stop the motor with the impulse switch – it always travels until reaching an end position. (Opened or closed position).
- for the function OPEN/CLOSE/OPEN we strongly suggest the installation of a photocell!

- **OPEN:** Only open commands are accepted of the impulse switch. Closing the gate with the impulse switch is not possible.
- **DEAD-MAN:** The motor opens as long as the impulse switch is pressed – closing the gate with the impulse switch is not possible. As soon as the switch is released, the gate stops. If hold to run operating mode is selected, the radio receiver slot (**FE**) is set out of order for reasons of safety.



IMPORTANT: Do not put into operation in dead man mode.
Select only after putting into operation ( page 25), if desired.



As impulse emitters pushbuttons or key switches as well as external radio receivers with potential free make contacts can be used.

⊙ **OPEN/ STOP / CLOSE impulse repetition:** An impulse through the pedestrian button-while the gate is in motion-causes gate stopping. If the gate is within the pedestrian area, then an impulse through the pedestrian button causes inversion of the direction.
If the gate is in complete open position an impulse through the pedestrian button causes a movement in CLOSE direction and the gate stops at pedestrian OPEN position.

○ **OPEN / CLOSE / OPEN impulse repetition:** If the gate is within the pedestrian area, then an impulse through the pedestrian button causes inversion of the direction.
If the gate is in complete open position an impulse through the pedestrian button causes a movement in CLOSE direction and the gate stops at pedestrian OPEN position.



- In this operation mode it is not possible to stop the motor with the pedestrian button – it always travels until reaching an end position. (Opened or closed position).
- for the function OPEN/CLOSE/OPEN we strongly suggest the installation of a photocell!

○ **OPEN:** Only open commands are accepted of the pedestrian opening button. Closing the pedestrian entry with the button is not possible.

○ **Impulse OPEN:** The contact at terminals 30/34 works as a second impulse button with the fixed adjustment „OPEN“.

○ **DEADMAN** (not selectable): As soon as the Impulse button is set to DEADMEN, automatically the pedestrian- and the CLOSE button are set to DEADMEN.

The motor opens as long as the pedestrian button is pressed – closing the gate with the pedestrian button is not possible. As soon as the switch is released, the gate stops.



As impulse emitters pushbuttons or key switches as well as external radio receivers with potential free make contacts can be used.

- A command with the CLOSE-switch engages closing of gate. In deadman mode the gate closes as long as the CLOSE-switch is pressed/switched. As soon as switch is released the gate movement stops.



As CLOSE-buttons you may use pushbuttons or key switches as well as external radio receivers with potential free make contacts can be used.

- when pressing the stop switch the gate stops in any desired position.



As stop switch a break contact has to be used.
If no stop switch is connected, terminals 31/37 have to be wire-bridged.

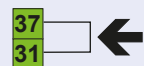

The stop input has no emergency stop function! - In order to ensure the emergency stop function, provide the supply line with an all-pole disconnecting emergency stop switch, that locks after actuation!



Photocells

- The control unit has a power supply connection for a 24V d.c. photocell (PHC):
supply PHC-transmitter: terminals 40/41 supply PHC-receiver: terminals 40/43.
Note: in „gate closed“ position the terminals 40/41 are being switched into energy saving mode (no current)
- The contact has to be closed when using powered and positioned photocells (opening contact).
Connection of the photocell contact: terminals 45/46

- When using two pairs of photocells please do not install both photocell transmitters/receivers on the same side (to eliminate interference between both) !

Exception: photocells with SYNC function allow the installation of both photocell transmitters/receivers on the same side without causing interference to each other.

Standard:

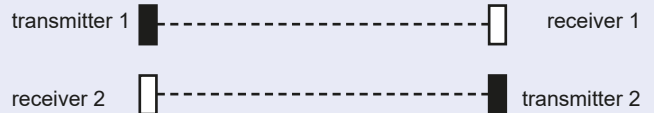

With SYNC-function:



- **Self-monitoring of photocells:** The control unit has a monitoring function for the connected photocells. A test will be triggered by each impulse and will be checked if the receiver of the photocell responds to the signal from the photocell transmitter. If there is no communication between the photocell receiver and transmitter the control unit responds with an error.
 ⚡ The deactivation of the self-test function is only permitted if the safety installations correspond to the category 3 !
- The exact function of the photocells depend on the programming of the control unit.
Photocell function please see menu point SAFETY / photocell function or photocell with pause time (➡ page 18)
- You will find detailed information in the corresponding photocell manual.

Ⓜ Photocell (Contact: terminals 45/46)

Safety

- Ⓞ **active:** to be selected, if photocell should be triggered.
- Ⓞ **not active:** to be selected, if photocell should not be triggered.

Photocell - connection examples

Photocell Tousek LS 26 as safety device



Important

- Jumper J of transmitter and receiver has to be adjusted in the same way.

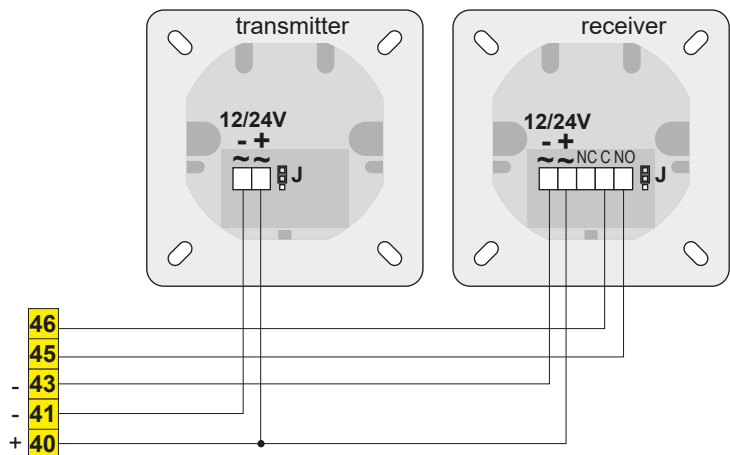

Photocell Tousek LS 41 as safety device

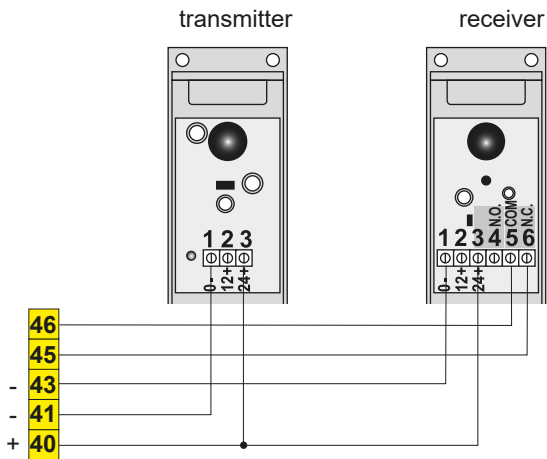

2 Photocells Tousek LS 41 as safety device

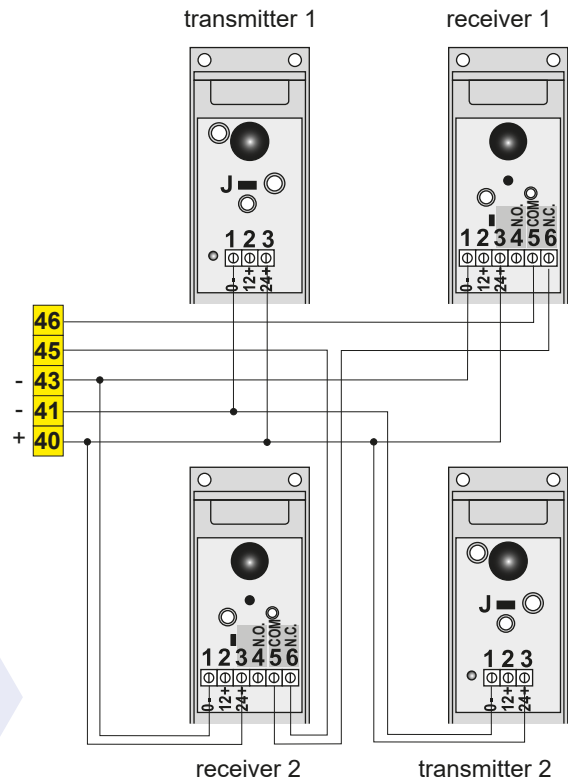

Deactivation of SYNC function

- The SYNC function with LS41 is **not possible** with this control unit. For deactivation of SYNC function, the jumpers **J** of both transmitters have to be connected (see picture). (see manual LS41)

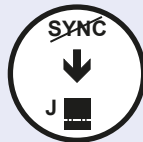

2 Photocells Tousek LS 45/2 as safety device

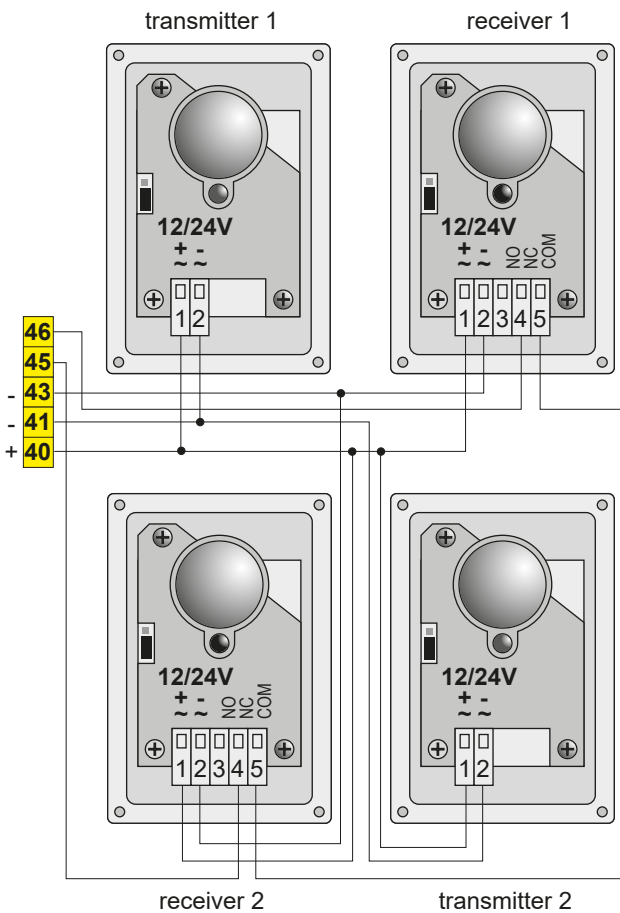

Photocells Tousek RLS 610 as safety device

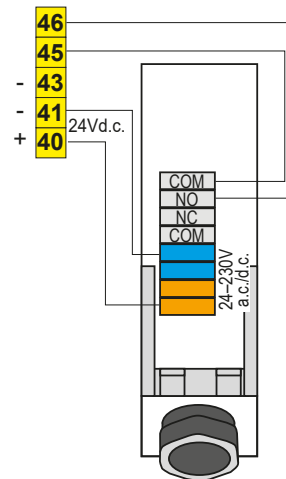



Safety sensing edges (main and side edge)

- **OBSTACLE DETECTION:** when a contact strip is triggered/activated then a change of direction is effected for 1 second. Then the gate stops.

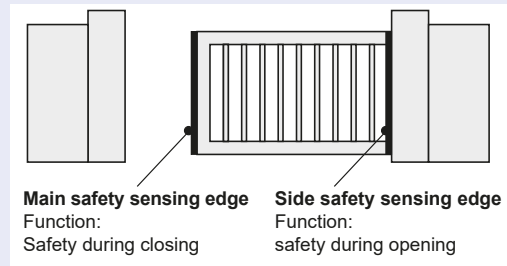

Hence if: safety edges that have to react on obstacles in closing movement have to be serially connected to the terminals of the main safety edge.

Safety edges that have to react on obstacles in opening movement have to be serially connected to the terminals of the side safety edge.

Example:

W	8,2kΩ final resistance
1	final edge
2+3	passage edge
S	to control board

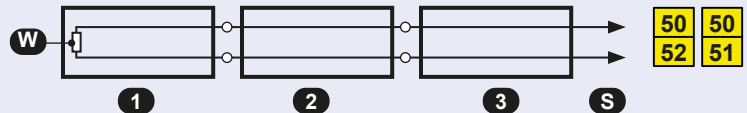

When connecting one safety edge a final edge (1) has to be used.

Main safety sensing edge
Side safety sensing edge



Important

- After giving the impulse to program the end positions, no other impulse must be given. Also the safety devices mustn't be triggered. This would lead to an interruption of the programming process.
- Therefore, the mechanical stops must be set so that the existing contact strips cannot be triggered.

Main safety edge (terminals 50/52)

Safety

- ⊙ **active:** to be selected if the contact strip (8,2kΩ) of main safety sensing edge should be evaluated.
- **radio edge TX:** to be selected if safety sensing edge (8,2kΩ) of main entrance edge should be evaluated **with the radio transmission system TX 310.**
- **TX 400:** to be selected if safety sensing edge (8,2kΩ) of main entrance edge should be evaluated **with the system TX 400i.**
- **not active:** to be selected if the contact strip of main safety sensing edge should NOT be evaluated

Side safety edge (terminals 50/51)

Safety

- ⊙ **active:** to be selected if the contact strip (8,2kΩ) of side safety sensing edge should be evaluated.
- **radio edge TX:** to be selected if safety sensing edge (8,2kΩ) of side entrance edge should be evaluated **with the radio transmission system TX 310.**
- **TX 400:** to be selected if safety sensing edge (8,2kΩ) of side entrance edge should be evaluated **with the system TX 400i.**
- **not active:** to be selected if the contact strip of side safety sensing edge should NOT be evaluated.



- Connection and detailed information of radio transmission system TX 310 see according manual.
- Connection and detailed information of inductive system TX 400i see according manual.

Photocell function

Safety

- ⊙ **when closing reverse:** an interruption of the photocell during closing makes the gate reverse (open). In automatic mode the gate closes as soon as the pause time has run out. In impulse operation another closing command has to be given.
- **stop - after release open:** an interruption of the photocell beam during opening or closing makes the motor stop as long as the photocell stays interrupted. After release of the photocell, the gate opens. In automatic mode the gate closes as soon as the pause time has run out, in impulse operation another closing command has to be given.
- **during close stop, then close:** an interruption of the photocell during closing makes the motor stop as long as the photocell stays interrupted. After release of the photocell, the gate opens.

PHC-pause time

Safety

- ⊙ **no influence of photocell:** the photocell doesn't have any influence on the pause time in automatic mode..
- **abort of pause time:** in automatic mode an interruption of the photocell during pause time shortens the pause time. After release of the photocell the gate starts closing.
- **re-start of pause time:** in automatic mode an interruption of the outer photocell during pause time, restarts the pause time. As soon as the pause time has run out, the gate closes.
- **immediate close after opening:** If the photocell is interrupted during the opening movement, the gate starts closing as soon as it reached end position open after release of the photocell.

PHC-self test

Safety

- ⊙ **active:** photocell self-test is executed with an opening impulse (switch, button) in gate position „closed“.
- **not active:** photocell self-test is not executed.



Attention

- The photocell self-test can only be deactivated by selecting „not active“.
- The deactivation of the self-test function is only permitted if the safety installations correspond to the category 3 !

max. force ☉ 100% (factory setting) Motor

- 50–100% adjustable [increment 5]: determines the max. possible motor force.

ARS response time ☉ 0,50s (factory setting) Motor

- 0,15–0,95s adjustable [increment 0,05]: determines, in which time the AR-System responds. The lower the value, the more sensitive the sensor will react.

speed ☉ 100% (factory setting) Motor

- 55–100% adjustable [increment 5]: determines the speed of motor.

soft stop way ☉ 0,5m (factory setting) Motor

- 0–2m adjustable [increment 0,1]: determines the distance of soft run.

soft speed ☉ 40% (factory setting) Motor

- 10–50% adjustable [increment 5]: determines the speed during soft run.

limit position OPEN ☉ -5 (factory setting) Motor

- 0...-30 adjustable [increment 1]: for readjustment of the automatically detected OPEN limit position of gate (e.g. for safety sensing barriers). With adjustment 0 the motor runs to the previously learned open position. For a diminished drive distance the value can be extended to up to -30.

This adjustment is ONLY adopted in CLOSED-position.

By deleting the limit positions in the menu „DIAGNOSIS / delete positions“ the adjusted value for „limit position OPEN“ will be deleted as well. The factory setting ☉ -5 will be saved.

limit position CLOSE ☉ -5 (factory setting) Motor

- 0...-30 adjustable [increment 1]: for readjustment of the automatically detected CLOSE limit position of gate (e.g. for safety sensing barriers). With adjustment 0 the motor runs to the previously learned close position. For a diminished drive distance the value can be extended to up to -30.

This adjustment is ONLY adopted in CLOSED-position.

By deleting the limit positions in the menu „DIAGNOSIS / delete positions“ the adjusted value for „limit position OPEN“ will be deleted as well. The factory setting ☉ -5 will be saved.

**Attention**

At force adjustment the valid safety regulations and standards have to be strictly followed !

Impulse mode

Operating mode

- ⊙ **stop, start of pause time:** An impulse during the opening movement stops the gate and starts pause time in automatic operation. When the pause time has run out, the gate closes automatically.
- **impulse suppression when opening:** Commands received during the opening movement are suppressed, commands during closing are accepted.
- **pause time extension:** A command during pause time restarts the pause time. If this menu point is chosen, an impulse suppression during opening is active at the same time.

G Opening direction

Operating mode

- ⊙ **<<<< left:** gate opens to the left side (seen from inside)
- **->>> right:** gate opens to the right side (seen from inside)

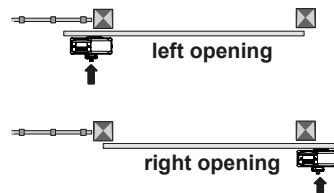

This adjustment is ONLY adopted in CLOSED-position.

G Operating mode

Operating mode

- ⊙ **Impulse mode:** Impulse through impulse switch/button or CLOSE-button to start closing of gate.
- **aut. close 1-255s adjustable [increment 1]:** gate closes automatically after the adjusted pause time
(Exception: [↗](#) see adjustment „Automatic mode“ / „only complete opening“).

Partial opening ⊙ 30% (factory setting)

Operating mode

- **10–100% adjustable [increment 1]:** value defines the partial opening of the total opening.

This adjustment is ONLY adopted in CLOSED-position

Automatic mode

Operating mode

- ⊙ **complete/partial opening:** either with complete as well as partial opening, the gate closes automatically after the adjusted pause time.
- **only complete opening:** only after complete opening, the gate closes automatically after the adjusted pause time.
Exception: If the gate is in partial open position and an impulse for complete opening arrives then the gate opens completely and after the pause time it returns to partial opening position.
- **only partial opening:** only after partial opening the gate closes automatically after the the adjusted pause time.

Pause time logic

Operating mode

- ⊙ **no influence**
- **always open in automatic mode:** If “always open in automatic mode” and “pause time” are simultaneous activated the automatic mode can be deactivated. An impulse in complete open position causes a switch into “impulse mode” but only for the current cycle. So the gate stays in OPEN position. The next impulse closes the gate and the control unit switches to “automatic mode” again. This function allows that the entrance of a company site stays open during the day (first impulse in complete open position). The gate can be closed with the second impulse e.g. in the evening (second impulse - for closing the gate and switching to the “automatic mode”). The control unit switches to the “automatic mode” again (automatic opening and closing of the gate).

Note: An impulse through the pedestrian button in the complete open position doesn't start the “always open” function. This action causes a movement in CLOSE direction and the gate stops at pedestrian OPEN position.

If the gate is in partial open position and „permanent open in automatic mode“ is selected, so it is possible to adjust permanent partial open for this cycle by giving an impulse via **pedestrian button**. Permanent partial open can be finished analogous to the above described method.



Warning

- Before connection works please turn off the main power switch !
- Safety rules please [page 13](#) !



Prewarning OPEN (Signal lamp: terminals 10/11)

Lights / Lamps

- ⊙ turned off
- **1–30s adjustable:** Before each opening movement the signal lamp/ flashing light is activated for the adjusted time.

Prewarning CLOSE (Signal lamp: terminals 10/11)

- ⊙ turned off
- **1–30s adjustable:** Before each closing movement the signal lamp/ flashing light is activated for the adjusted time.



Signal lamp

- a signal lamp can be connected to the terminals 10/11 (230V, max. 100W).

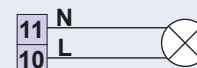

Additional module (Description add. modules [page 22](#))

Lights / Lamps

- ⊙ **yard/control light:** the menu points courtyard lamp and control lamp are ready for adjustment (that means if not selected, these menu points will not be shown on the display)
- **status display 1:** with the two potential-free signal contacts K1 and K2, the gate end positions (limits) can be evaluated.
- **status display 2:** with the two potential-free signal contacts K1 and K2, the gate end positions (limits), the gate movement as well as a gate stop outside of the end positions can be evaluated.

		Function	K1	K2
Gate status display	1	Gate in CLOSE-Position	1	0
		Gate in OPEN-Position	0	1
Gate status display	2	Gate in CLOSE-Position	0	0
		Gate opens or closes	0	1
		Gate stopped or fault	1	0
		Gate in OPEN-position	1	1

0 = signal contact open, 1= signal contact closed



- You will need for use of adjustments one of the selected adjustments (courtyard-/control I hence gate status 1 or 2.

The following two menu points can only be selected if the menu point additional menu is adjusted to „Courtyard-/Control lamp“ (hence shown on display).

Courtyard light (Description add. modules [page 22](#))

Lights / Lamps

- ⊙ turned off
- **5–950 adjustable:** at the courtyard lamp output an external lamp can be connected (e.g. garden lamp), which can be turned on for each opening command for the duration of adjusted time.

Pilot (control) lamp (Description add. modules [page 22](#))

Lights / Lamps

- ⊙ **illuminates when opening/closing:** The pilot lamp output is activated during opening- and closing movement.
- **blinks slowly / illuminates / blinks:** The pilot lamp output is activated as follows: During opening the pilot lamp flashes slowly. During pause time, in opened position or when the gate stops it is illuminated. During the closing movement it flashes rapidly. If the gate is closed, the pilot lamp expires
- **illuminates in open position:** Pilot lamp is illuminated as soon as the gate has reached end position open.



Additional module Courtyard lamp/control lamp hence gate status display

- The use of one of the additional modules is optional.
- Depending on which device, e.g. a courtyard-/Control lamp is chosen or evaluation of gate status should be effected, the corresponding module has to be plugged to the according slot/plug of control board.
- Additionally the corresponding value has to be selected in menu point „Additional module“.

Connecting an additional module

- turn off power supply ! 
- Cut out the marked area (6b).
- Plug additional module (Z) through opening onto the slot (ZM).

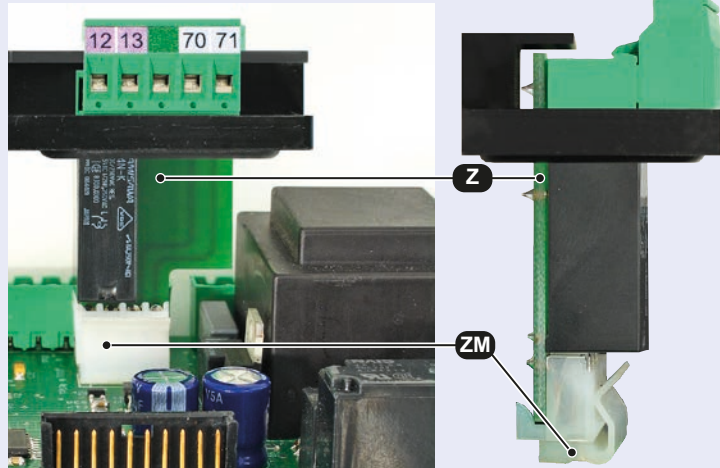
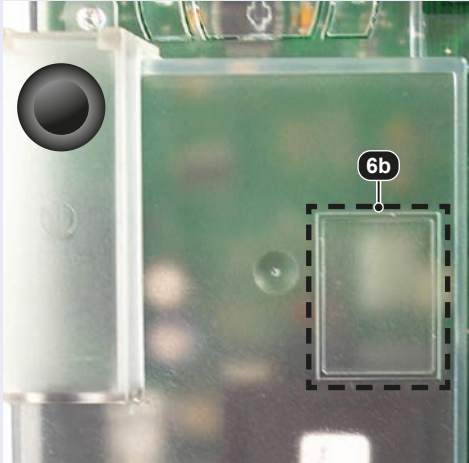

Additional module Courtyard lamp/Control lamp

- On the potential free contact (12/13) a courtyard lamp can be connected: **230V, max. 100W**
- On the terminals 70/71 a control lamp can be connected: **24Vd.c., max. 2W**

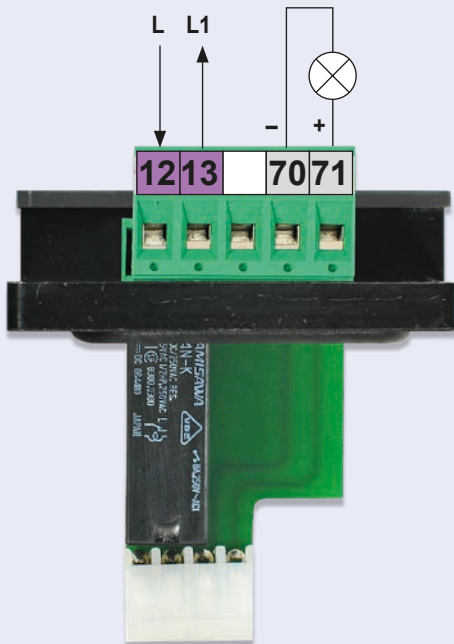

Additional module Gate status display

- with potential free signal contacts K1 (KI. 90/91) and K2 (KI. 92/93) the gate status can be evaluated in two ways (see menu point „Additional module“).
- Contact load: **24Va.c./d.c., max. 10W**

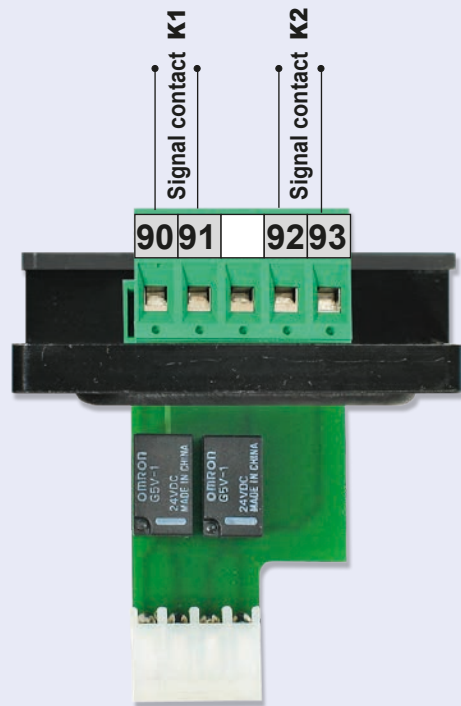





Status display

Diagnose

➔ Status display for inputs as photocell, safety sensing edges, stop button, impulse switch

- I Impulse-button
- P pedestrian entry
- C CLOSE-button
- S STOP-button
- Ph photocell contact
- ME main safety edge
- SE side safety edge

-  Status: not triggered
-  Status: triggered
-  Status: contact strip not connected or defect
-  Status: contact strip or photocell deactivated in menu

for example

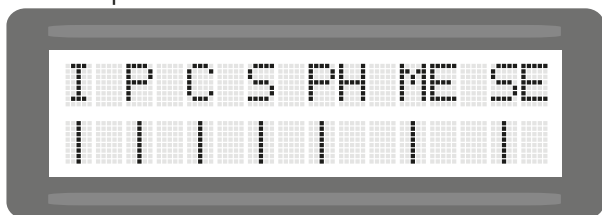

All inputs okay.



Impulse-, pedestrian - and close button not triggered. STOP-button and photocell are triggered. Contact strip (main closing edge) not connected or defect. contact strip (side closing edge) triggered.

Delete position

Diagnosis

- ⊙ NO: does not delete the end positions “gate closed” and “gate open”
- YES: the determined end positions are being deleted. Note: the end positions will be determined after new impulse.



The mechanical stops have to be placed so that possibly existing safety contact edges can not be triggered, as this would lead to an error message.

Factory setting

Diagnosis

- ⊙ NO: no reset back to factory settings
- YES: reset back to factory settings



Note: The factory settings of the single menu points are marked with ⊙ in this manual.

Software version

Diagnosis

➔ shows the software version on display

Serial number

Diagnosis

➔ shows the serial number on display

Protocol

Diagnosis

➔ shows the protocol list on display: all events that take place are protocolled in this list - with the buttons + and - the single events can be seen:

With * the protocol beginning hence the end is shown

Time since the last event:
DAYS HOURS : MINUTES : SECONDS

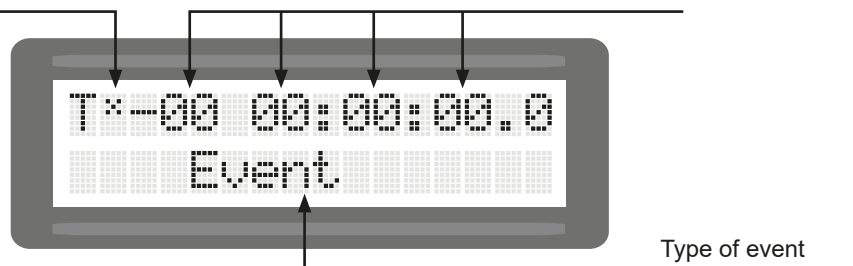

Status Sensor

Diagnosis

➔ Degree and signal strength of rotation speed sensor is shown on display.

4. Connecting the receiver

Sliding gate operator PULL T24, -T24speed

- Disconnect the power supply. 
- Remove radio cover (6a) after loosening the bolt (S).
- Plug-in the receiver printed circuit board (E) RS433/868-STN1 (1 channel) or RS433/868-STN2 (2 channels) into the corresponding slot (FE) as shown in the picture.
- Slide the antenna cable (D) through the output connection (A).
- Place the radio cover (6a) back and fix it with bolt (S).
- To increase the range an external antenna FK433 or FK868 can be connected.



Important

- With the use of the 2-channel-receiver the second channel takes over the function of the pedestrian entry mode switch.
- For programming of receiver please *see manual for radio receiver*.

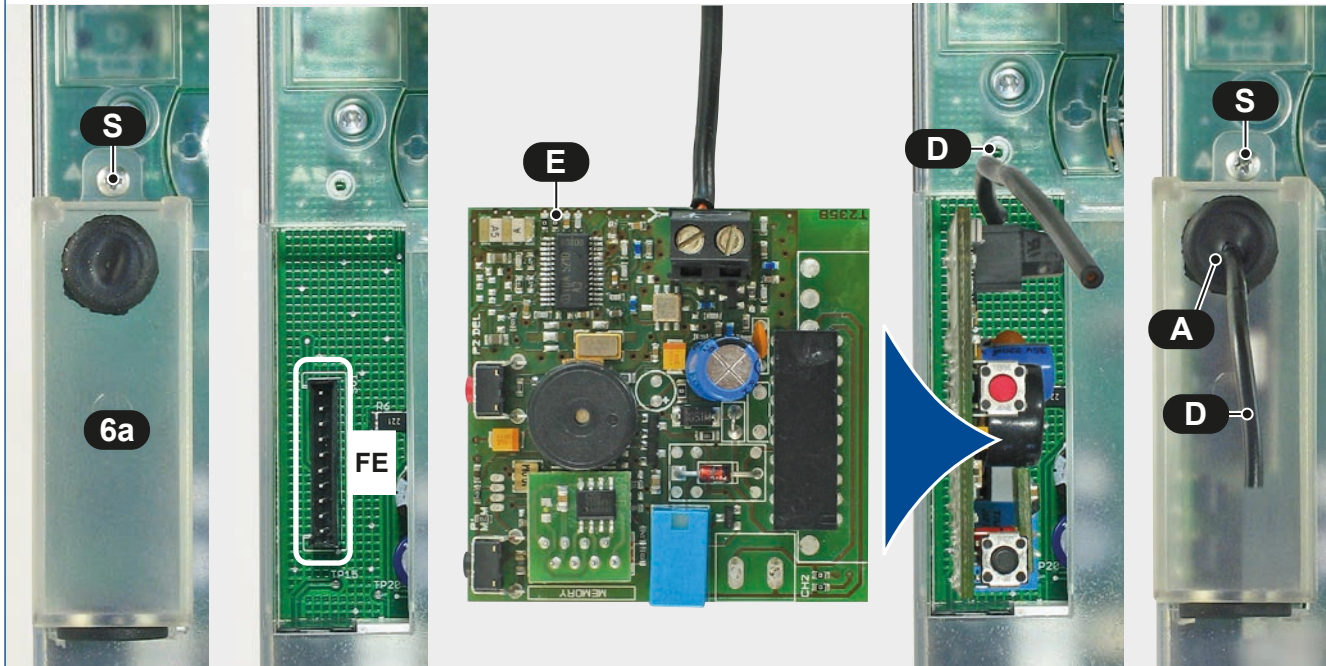

Important notes after installation

- Installation, connection, adjustments, putting into operation, and servicing may only be carried out by trained professionals in full accordance with these installation- and operating instructions.
- The packaging materials (cardboard, plastic, EPS foam parts and filling material etc.) have to be properly disposed of in accordance with the applying recycling and environmental protection laws. They may be hazardous to children and therefore have to be stored out of children's reach.
- The product is not suitable for installation in explosion-hazardous areas.
- The product may only be used in accordance with its original purpose, for which it has been exclusively designed, and which is described in these installation and operating instructions (especially children have to be instructed). The TOUSEK Ges.m.b.H. rejects any liability if the product is used in any way not fully conforming to its original purpose as stated herein.
- All electrical installations have to be made in full conformity with the applying rules and laws (e.g. using a fault current circuit breaker, proper grounding etc.).
- An all-pole disconnecting main switch with a contact opening-gap of minimum 3 mm has to be foreseen.
- The electric motor heats up during operation. Therefore the device should only be touched after it has cooled off.
- After installation the proper function of the gate facility and the safety devices has to be checked!
- The installer has to inform the user about all aspects of the automatic operation of the complete gate facility, as well as about emergency operation. The installer further has to supply to the user all instructions relating to the safe operation



Important: preparation works

- Connect control panels, safety devices to the motor in compliance with the safety regulations.
Attention: if no stop switch is connected then the terminals 31/37 have to be bridged.
 - **The mechanical limits have to be placed so that contact edges are not triggered, as this would lead to an error message.**
 - Unlock emergency release of operator and set gate to half-opened position. Then lock the operator again.
 - Switch on the system (assuming proper connection).
 - **Important:** Putting into operation in Impulse mode (standard setting) and not in dead man mode.
 - During initial operation the choice of language is made first, then in the “Basic settings” the adjustment of most important operator settings and after the system test, the automatic detection of limit positions of gate is made.
- Note: during operation with the basic setting for limit positions OPEN/CLOSE (=5), the limit stops will not be reached (only with adjustment = 0)**

LANGUAGE SELECTION

- Can be selected during initial operation (hence after reset to factory settings).
- Can be also chosen by pressing the ESC button (↵) for 5s, from any position in menu.

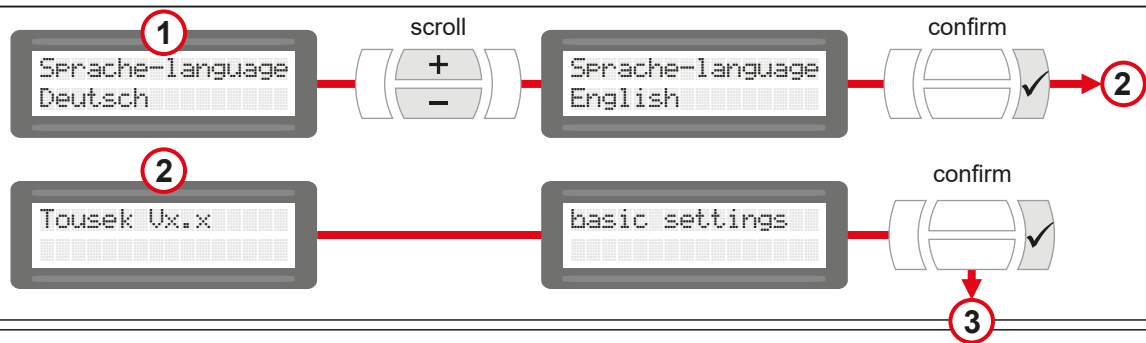

BASIC SETTINGS

- For setting the most important adjustments for initial operation of motor.
- Can be selected during initial operation (hence when restoring the factory setting).
- All safety devices are activated when leaving factory (→ page 12).
- The next programming adjustments are made in the main settings menu (→ page 11, 12).

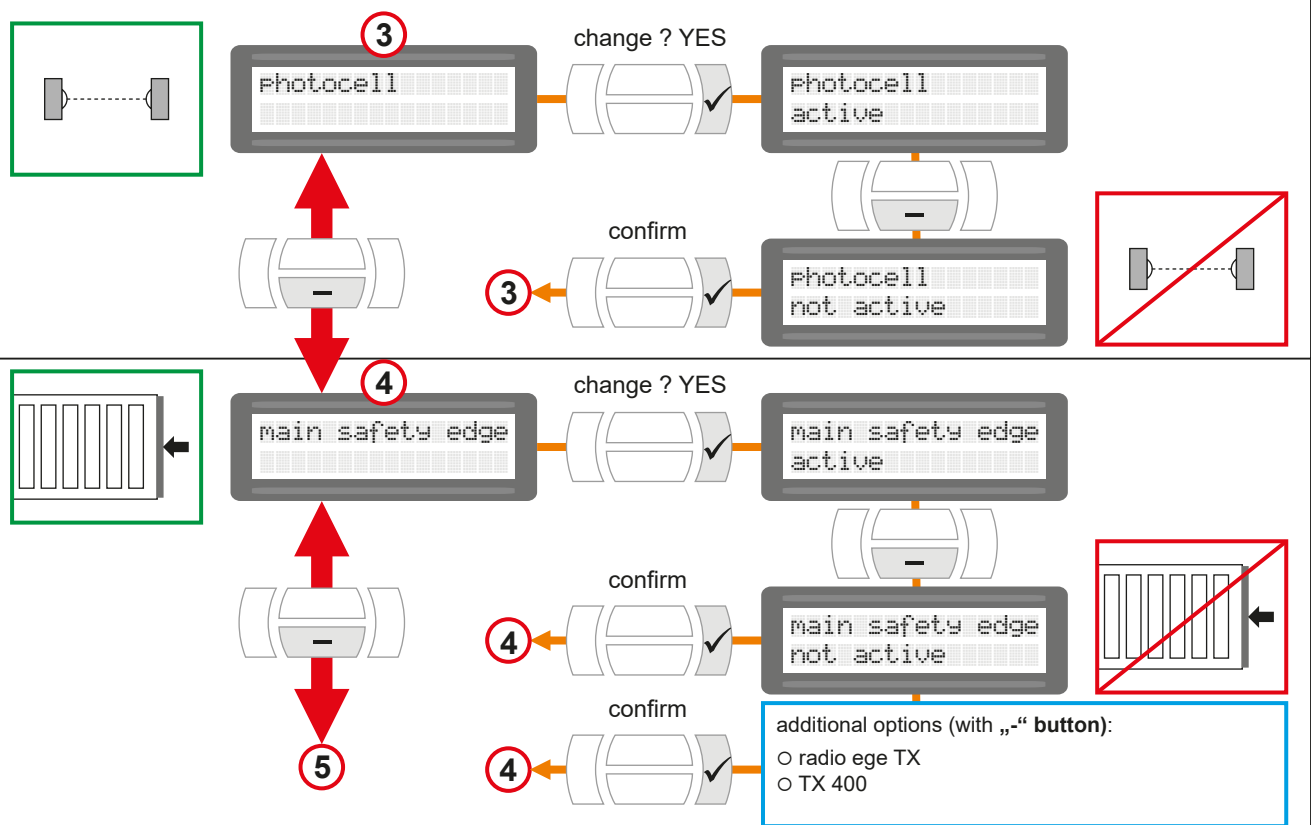

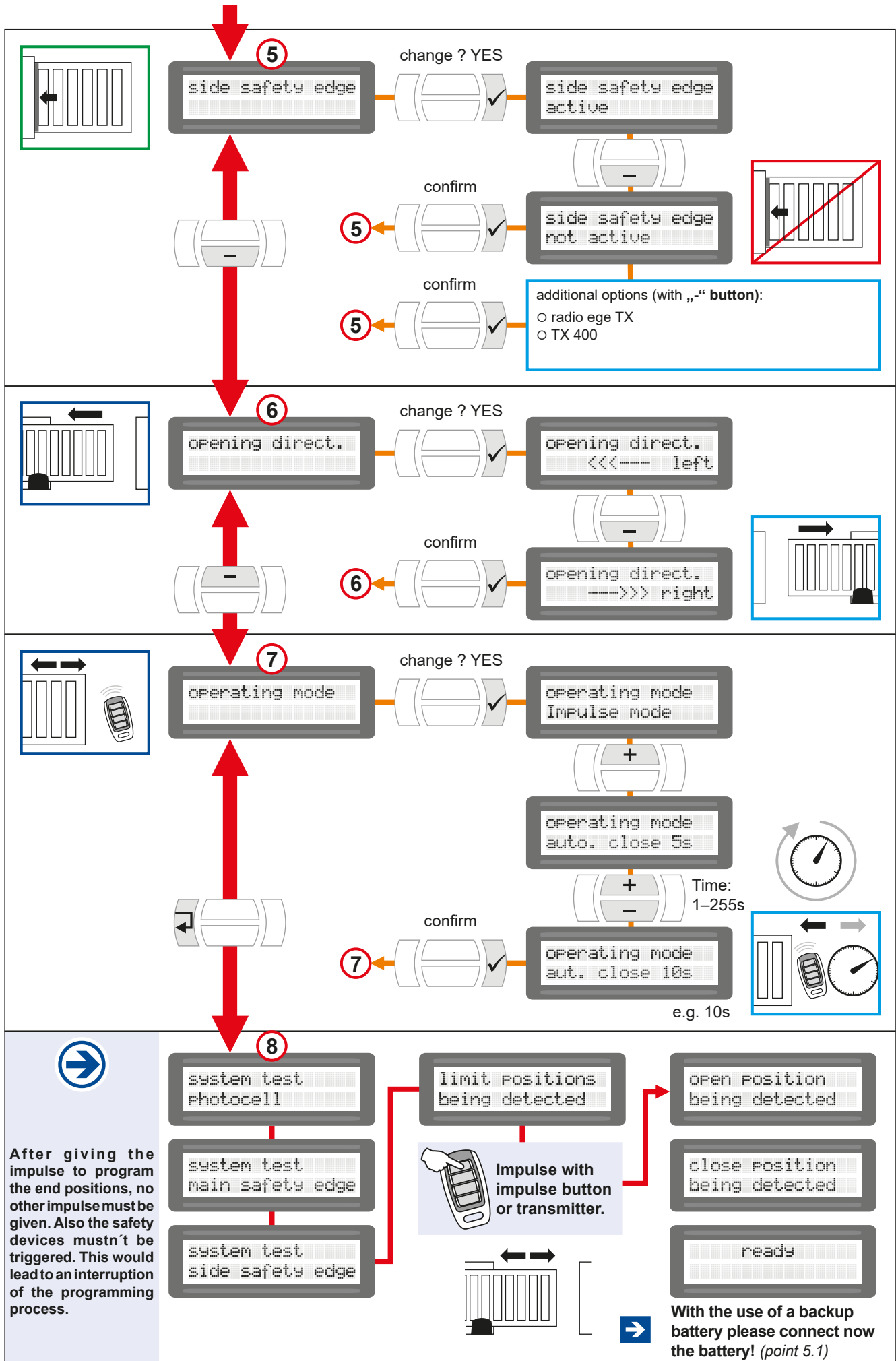



Important for use with emergency battery

- The motor can be equipped with an additional optional battery (NB), which can be integrated into the operator.

IMPORTANT BEFORE CONNECTION OF BATTERY:

- Mount the operator completely.
- Make the electric wiring incl. 230V connection.
- Make sure that there is a 230V power supply before connecting the battery.
- Disconnect the 4pol. clamp block (KL).
- Grey battery cable (- Pol) → connect to control terminal 18.
- Remove protection tube (S) of yellow battery cable.
- Yellow battery cable (+ Pol) → connect to control terminal 19.
- Connect the 4pol. clamp block (KL) again.

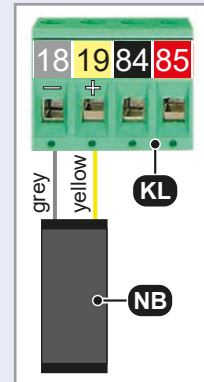

IMPORTANT

- Make the battery connection with great care, so that there is no short-circuit (the battery is pre-loaded !)
- Make sure that there is a 230V power supply before connecting the battery
- For repair and maintenance works please remove first the clamp block/terminal (KL) and then turn off the 230V power supply !
- When reconnecting again first turn on the 230V power supply and then attach the clamp block/terminal (KL).



battery set (Art.No. S35116)

Error	possible reason	solution
Display: „Stop-button released“	stop-button not connected or not bridged	Stop-button (KI.) connect or bridge > use status display for help
Display: „Photocell released“	photocell interrupted	check correct connection hence remove obstacle > use status display for help
Display: „Main safety sensing edge released“	main safety edge interrupted or hot-wired	check correct connection hence remove obstacle > use status display for help
Display: „Side safety sensing edge released“	Side safety sensing edge interrupted or hot-wired	check correct connection hence remove obstacle > use status display for help
Display: „AR-System released“	Gate ran into an obstacle or is too hard to move	check adjustment of forces, remove obstacle hence check if gate is easy to move
Display: „photocell test negative“	interruption or hot-wired photocell	check correct connection hence remove obstacle > use status display for help
Display: „main safety edge test negative“ (only when using the TX 310)	Short-circuit or interruption of main safety edge	check correct connection hence battery status of transmitter > use status display for help
Display: „side safety edge test negative“ (only when using the TX 310)	Short-circuit or interruption of side safety edge	check correct connection hence battery status of transmitter > use status display for help
Display: „Low voltage“	undervoltage	check supply line
Display: „motor overcharge triggered“	gate is too hard to move	check the mechanics of the gate, make sure it is smooth-running
No reaction when giving an impulse	no line voltage hence safety fuse broken	check line voltage as well as safety fuses
	error of transmitter/control device/impulse button, e.g. transmitter not programmed	check transmitter/control device, e.g. program transmitter and check battery

8. Dimensioned drawing

Sliding gate operator PULL T24, -T24speed

- Dimensions in mm

- (1) lockable emergency release (euro standard cylinder)
- (2) gear wheel
- (3) cable entrance
- (4) ground plate
- (4a) slotted holes (4x) for mounting on foundation
- (5) display for programming

PULL	-T24	-T24speed
¹⁾ gear wheel	Z16M4, r36	Z20M4, r44
²⁾ gear wheel center	63	
³⁾ gear wheel top	99	107

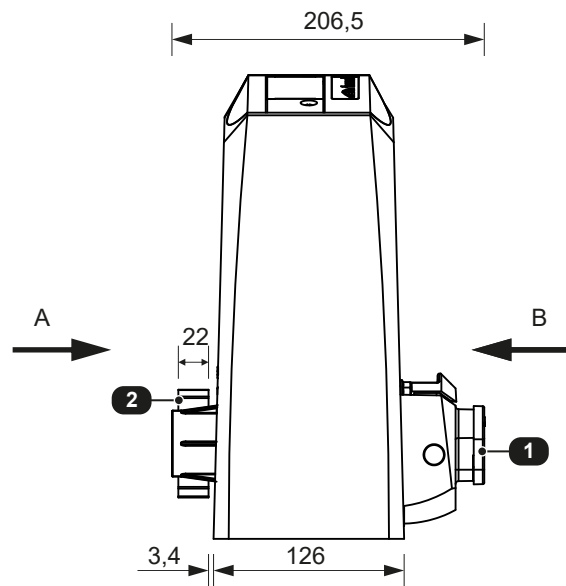

View B:

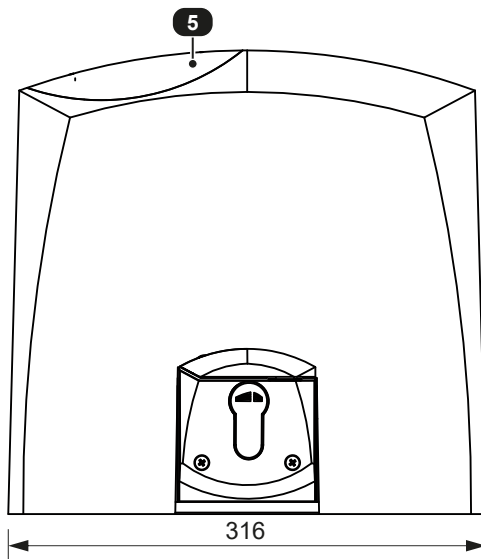

View A:

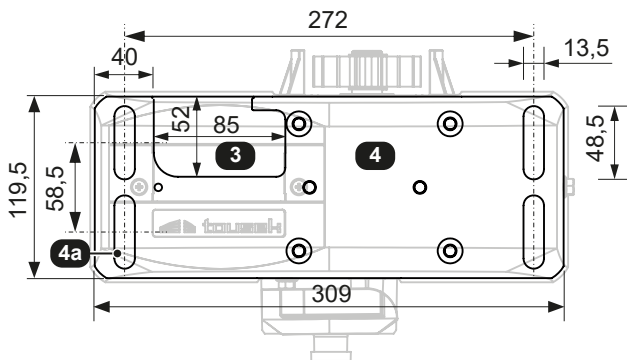
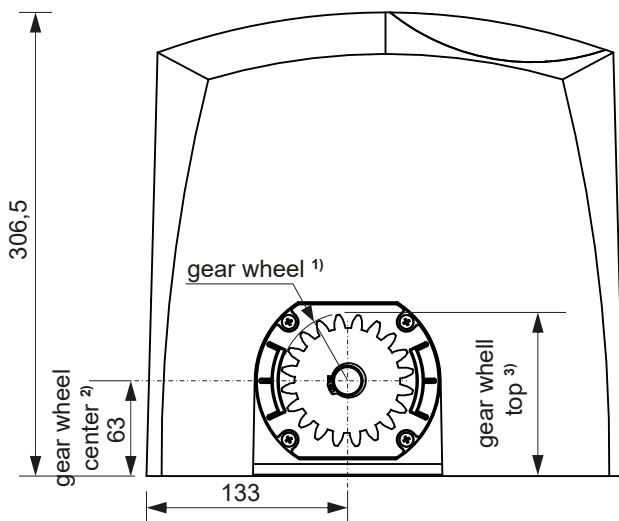

We reserve the right to change dimensions and technical specifications without prior notice.



Declaration of incorporation

In compliance with EC Machine Directive 2006/42/EC, Annex II B for the installation of an incomplete machine.

We hereby declare that the following product, as well as its version, put by us into circulation, complies with the essential requirements of the Machinery Directive (2006/42/EC), due to its design and type of construction.

The validity of this declaration will cease in case of any unauthorized modifications to the products.

The product:

Sliding gate opener PULL-T4speed, -T5, -T8, -T10, -T15, -T24, -T24speed, -T5SE, -T8 Master/Slave, -T8A, -TSA

is developed, designed and manufactured in accordance with:

Machinery Directive 2006/42/EG
Low Voltage directive 2014/35/EU
Electromagnetic compatibility 2014/30/EU

Applied and used standards and specifications:

EN ISO 13849-1, PL-,c", Cat 2
EN 60335-1 as applicable
EN 60335-2-103
EN 61000-6-3
EN 61000-6-2

Following requirements of Annex I of the EC Directive 2006/42/EC are met:

1.1.2, 1.1.3, 1.1.5, 1.2.1, 1.2.2, 1.2.3, 1.2.6, 1.3.2, 1.3.4, 1.3.7, 1.5.1, 1.5.4, 1.5.6, 1.5.8, 1.7

The relevant technical documentation is compiled in accordance with Annex VII, Part B of the EC Machinery Directive 2006/42/EC.

We undertake to submit it in electronic form and within a reasonable time to the market surveillance authorities in response to a duly substantiated request.

TOUSEK Ges.m.b.H., A1230 Wien, Zetschegasse 1, Österreich

is authorized to compile the technical documentation.

The incomplete machine cannot be put into service, until it is determined that the machine, into which the incomplete machine has to be inserted, complies with the the Machine Directive 2006/42/EC.

Eduard Tousek, CEO

Vienna, 11. 08. 2020

EC Declaration of Conformity

In compliance with EC Machine Directive 2006/42/EC, Annex II, Part 1 A.

When the described operators are connected to a gate they form a machine in the sense of the EC Machine Directive.

Relevant EU directives:

Construction Products Directive 89/106/EWG
Machinery Directive 2006/42/EG
Low Voltage directive 2014/35/EU
Electromagnetic compatibility 2014/30/EU

We hereby declare that the following product, in the version put by us into circulation, complies with the essential requirements of the Directives mentioned above. The validity of this declaration will cease in case of any unauthorized modifications to the products.

Product:

Gate description

Motor description

The incomplete machine cannot be put into service, until it is determined that the machine, into which the incomplete machine has to be inserted, complies with the the Machine Directive 2006/42/EC.

Installation company

Address, ZIP code, Place

Date/ Signature

Motor number (Type plate): _____

Other components:

tousek PRODUCTS

- sliding gate operators
- cantilever systems
- swing gate operators
- garage door operators
- folding door operators
- traffic barriers
- electronic controls
- radio remote controls
- key operated switches
- access control
- safety devices
- accessories

Tousek Ges.m.b.H. Austria
A-1230 Vienna
Zetschegasse 1
Tel. +43/ 1/ 667 36 01
Fax +43/ 1/ 667 89 23
info@tousek.at

Tousek GmbH Germany
D-83395 Freilassing
Traunsteiner Straße 12
Tel. +49/ 8654/ 77 66-0
Fax +49/ 8654/ 57 196
info@tousek.de

Tousek Benelux NV
BE-3930 Hamont - Achel
Buitenheide 2A/ 1
Tel. +32/ 11/ 91 61 60
Fax +32/ 11/ 96 87 05
info@tousek.be

Tousek Sp. z o.o. Poland
PL 43-190 Mikołów (k/Katowic)
Gliwicka 67
Tel. +48/ 32/ 738 53 65
Fax +48/ 32/ 738 53 66
info@tousek.pl

Tousek s.r.o. Czech Republic
CZ-252 61 Jeneč u Prahy
Průmyslová 499
Tel. +420 / 777 751 730
info@tousek.cz

tousek

EN_PULL-T24-T24speed_49002411
27. 10. 2021



tousek[®]
G A T E A U T O M A T I O N

your service partner:

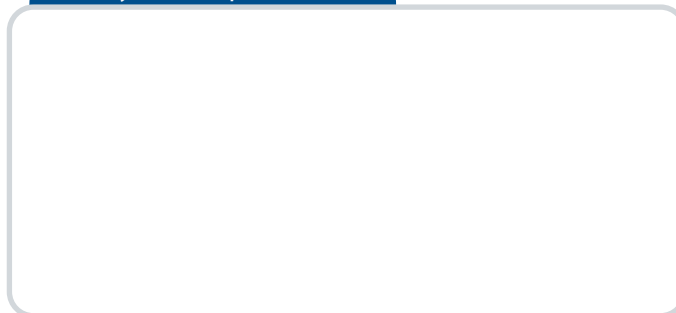

We reserve the right to change dimensions and/or technical specifications without prior notice. Claims resulting from misprints or errors cannot be accepted.

